

STREETSCAPE COLLECTION

45 GALLON OUTDOOR TRASH RECEPTACLE W/ FLAT TOP AND RAIN CANOPY (SCTP-40-D ND)

SELECT DESIRED STANDARD FINISH:

- COFFEE GLOSS
- HUNTER GREEN GLOSS
- BLACK GLOSS
- CUSTOM (ANY RAL COLOR MATCH)

MANUFACTURER NOTES:

- BODY AND BOTTOM, 3/16" X 1.5" STEEL BARS. COMPLETELY WELDED CONSTRUCTION.
- PREPARED IN 5 STAGE PRETREATMENT AND ELECTROSTATICALLY POWDER COATED WITH TGIC POLYESTER POWDER COATING 2-3 MIL THICKNESS. MULTIPLE COLORS AVAILABLE.
- UL-94 RATED RIGID LEAKPROOF LINER, 45 GALLON CAPACITY. BLACK, LLDPE WITH CUT OUT LIFT HANDLE AND BAG RETENTION HOLES.
- UNIT SITS ON 4 ADJUSTABLE LEVELING FEET.
- DOME / LID IS ATTACHED TO UNIT WITH A PVC COATED LANYARD CABLE
- GROUND MOUNTING KIT IS INCLUDED (CONCRETE ANCHOR, 5/16-18 x 2" HEX BOLT AND 3/8 FLAT WASHER).

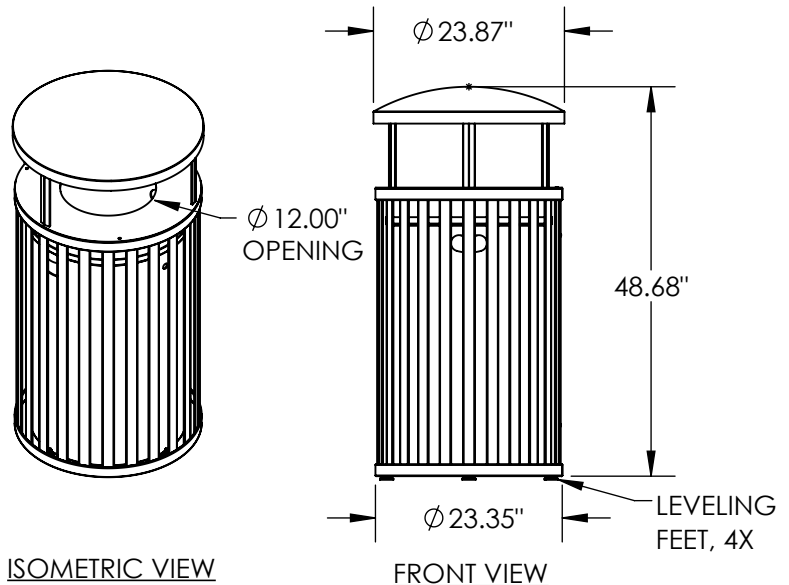

ISOMETRIC VIEW
45 GALLON RECEPTACLE

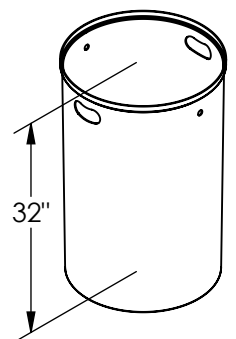

ISOMETRIC VIEW
45 GALLON LINER

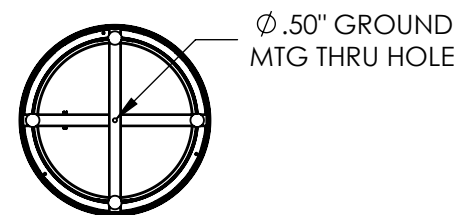

BOTTOM VIEW

NOTES:

1. INSTALLATION TO BE COMPLETED IN ACCORDANCE TO WITH MANUFACTURER'S SPECIFICAITONS.
2. DO NOT SCALE DRAWING.
3. THIS DRAWING IS INTENDED FOR USE BY ARCHITECTS, ENGINEERS, CONTRACTORS, CONSULTANTS AND DESIGN PROFESSIONALS FOR PLANNING PURPOSES ONLY. THIS DRAWING MAY NOT BE USED FOR CONSTRUCTION.
4. ALL INFORMATION CONTAINED HEREIN WAS CURRENT AT THE TIME OF DEVELOPMENT BUT MUST BE REVIEWED AND APPROVED BY THE PRODUCT MANUFACTURER TO BE CONSIDERED ACCURATE.
5. CONTRACTOR'S NOTE: FOR PRODUCT AND COMPANY INFORMATION, VISIT www.CADdetails.com/info AND ENTER REFERENCE NUMBER