

INSTRUCTION SHEET

The Travelers Series™ Bellmans Cart

Model# 780 EC

Made in USA

To Install Casters

1. Unpack carpeted deck, and turn upside down on work surface.
2. Unpack casters, and place on undercarriage locating the two rigid wheels on one side and two swivel wheels on the opposite end. Bolt each wheel with 4-3/8-16 x 3/4" hex head machine bolts and split-lock washer.

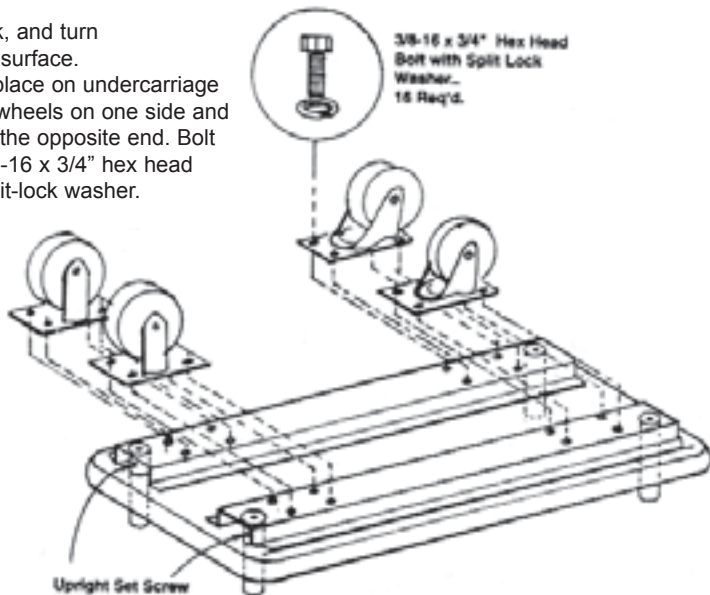

To Assemble Uprights

1. Unscrew the upright set screw from each of the lower supporting tubes on the deck.
2. Turn deck to its upright position and insert an upright assembly in each end, and tighten the lower set screw, one in each leg.
3. Remove mounting screws, 1/4-20 x 2-1/2" oval head, from top bar/brace assembly (4 total).
4. Position top bar assembly between the two uprights and replace mounting screws. The top bar should be in the upper hole, with the brace in the lower hole.

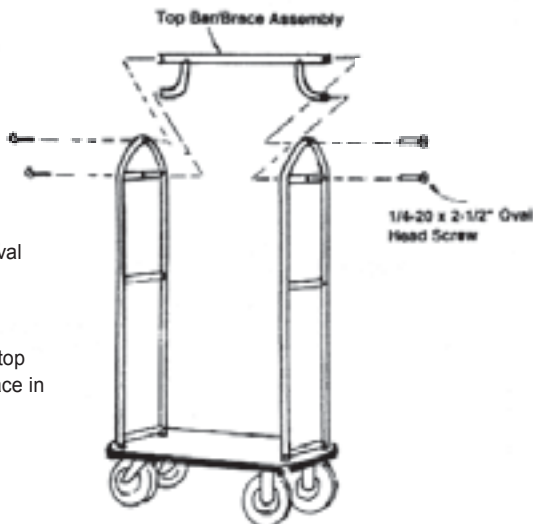

INSTRUCTION SHEET

The Travelers Series™ Bellmans Cart

Model# 780 EC

Made in USA

To Install Casters

1. Unpack carpeted deck, and turn upside down on work surface.
2. Unpack casters, and place on undercarriage locating the two rigid wheels on one side and two swivel wheels on the opposite end. Bolt each wheel with 4-3/8-16 x 3/4" hex head machine bolts and split-lock washer.

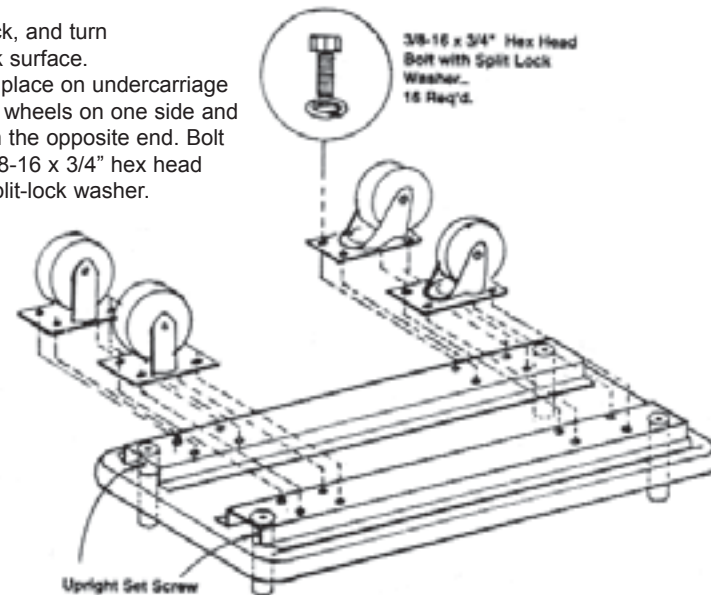

To Assemble Uprights

1. Unscrew the upright set screw from each of the lower supporting tubes on the deck.
2. Turn deck to its upright position and insert an upright assembly in each end, and tighten the lower set screw, one in each leg.
3. Remove mounting screws, 1/4-20 x 2-1/2" oval head, from top bar/brace assembly (4 total).
4. Position top bar assembly between the two uprights and replace mounting screws. The top bar should be in the upper hole, with the brace in the lower hole.

